



Wall-mounted LV Energy Storage Battery

USER MANUAL

DHN-LVWES05/15-G1



ABOUT THIS MANUAL

This manual contains important instructions for the DHN-LVWES series energy storage batteries. Users should read this manual thoroughly before installation or commissioning. For safety reasons, technicians responsible for installing and maintaining this system must have relevant qualifications, receive relevant training, master relevant skills, and strictly follow the instructions contained in this document.

ADDITIONAL INFORMATION

Product information is subject to change without prior notice. The user manual will be updated regularly. Please visit DAH Solar official website www.dahsolar.com to obtain the latest version.

1 - IMPORTANT NOTES

1.1 Safety Instructions





DAH Solar DHN-LVWES series energy storage batteries have been designed and tested according to international safety requirements. However, safety regulations must still be followed during installation and operation. Installers must carefully read, fully understand and strictly follow all instructions, precautions, and warnings in this user manual.

1.2 Precautions

Before operating the equipment in the system, ensure that the equipment is powered off to eliminate the risk of electric shock. Always adhere strictly to this manual when operating the equipment.

- The energy storage inverter used with the battery must be in the corresponding energy storage inverter whitelist of DAH Solar.
- Do not disassemble, modify, or repair the battery without official authorization from DAH Solar. Failure to comply may result in the risk of electric shock or equipment damage. Any resulting losses will not be covered by DAH Solar's responsibility.
- Do not hit, pull, drag, crush, or step on the device, and do not place the battery in fire as there is a risk of the battery exploding.
- Do not place the battery in a high-temperature environment. Ensure that there are no heat sources near the battery and that it is not exposed to direct sunlight. A fire may occur if the ambient temperature exceeds 60°C.
- Do not use a battery if it is visibly defective, cracked, damaged, or otherwise in any condition. Damaged batteries may cause electrolyte leakage.
- To protect the battery pack and its components from damage during transportation, please ensure that the transport personnel are professionally trained. During transportation, record the operation steps and keep the device balanced to prevent it from falling.
- Battery equipment is heavy, so please assign personnel according to the weight of the equipment to prevent the equipment from exceeding the weight range that can be carried by humans and causing injuries to personnel.
- If the battery fails to start, contact your dealer as soon as possible. Otherwise, the battery may be permanently damaged.
- Do not move the battery system while the battery is working. If you need to replace or add batteries, please contact your dealer.

1.3 Explanation of Symbols

SYMBOL	USE
	Please read the manual first user manual before installing, operating and maintaining the battery .
	Disposal In order to comply with the European Directive 2002/96/EC on Waste Electrical and Electronic Equipment and other electronic equipment disposal regulations implemented as national laws, electrical equipment that has reached the end of its useful life must be collected separately and sent to approved recycling plants. If the battery is in a waste state, it must be returned to an authorized dealer or an approved recycling plant.
	High voltage danger the battery can be life-threatening.
	Notice There is a risk of electric shock when the product is converting energy. Do not perform any operation before the residual voltage is released. the battery is working, no one is allowed to enter within 20 cm.
	CE Marking The battery complies with the EU Low Voltage Directive.
UN38.3	UN38.3 certification mark The battery has been rigorously tested in accordance with relevant UN standards and has been proven to meet safety requirements during transportation.

1.4 Emergency Measures

Battery electrolyte leakage	<p>If the battery module leaks electrolyte, avoid contact with the leaked liquid or gas. The electrolyte is corrosive and contact may cause skin irritation and chemical burns. If you accidentally come into contact with the leaked material, do the following:</p> <ul style="list-style-type: none">• Inhalation: Evacuate from contaminated area and seek medical help immediately.• Eye contact: Rinse with water for at least 15 minutes and seek medical help immediately.• Skin contact: Wash exposed area thoroughly with soap and water and seek medical help immediately .
Fire	<ul style="list-style-type: none">• When the battery temperature exceeds 150 ° C, there is a risk of fire, and toxic and harmful gases may be released after the battery catches fire.• To prevent fire hazards, ensure that a CO2, Novac 1230, or FM-200 fire extinguisher is available near the equipment.• When extinguishing a fire, do not use an ABC dry powder fire extinguisher. Firefighters must wear protective clothing and self-contained breathing apparatus.

2- PRODUCT INTRODUCTION

2.1 Product Description

DAH Solar DHN-LVWES series is a low-voltage energy storage battery designed to provide efficient and reliable energy storage solutions for homes, businesses and specific occasions. It uses Lithium Iron Phosphate batteries from first-line brands in the industry, with high safety, high stability, high energy density and long cycle life. It has a built-in efficient intelligent battery management system to fully monitor and control the battery energy storage system to ensure its safe, stable and high-performance operation.

2.2 Features

Safe	<ul style="list-style-type: none">• A-grade lithium iron phosphate battery with high safety performance.• Intelligent BMS with multiple safety functions, making it safer to use.• Fire Protection System: Optional pre-setting fire extinguisher.
Long Life-time	<ul style="list-style-type: none">• Cycle life of over 6000/8000 cycles (70% SOH).• High parallel balancing current to ensure battery consistency.
Convenient & Smart	<ul style="list-style-type: none">• Bluetooth/Wi-Fi function, support real time monitor and remote software upgrade by APP• Support Bluetooth/Wi-Fi inverter protocol configuration function, quickly set-up and easy to operate• Automatic networking of battery modules (without DIP switch codes), easy to maintain.
Flexible	<ul style="list-style-type: none">• Modular design, easy to expand, up to 16 parallel batteries.• Small size, high power density.• Wall mounted with bracket installation, floor standing with bracket or caster installation, saving installation space.• Match with mainstream low-voltage energy storage inverters.
One-stop Service	<ul style="list-style-type: none">• DAH Solar provide integrated system configuration services from PV to energy storage.

2.3 Dimensions

Model	Width, Height and Depth	
DHN-LVWES05-G1	480×500×155mm	
DHN-LVWES15-G1	520×680×232mm	

2.4 Interface Definition

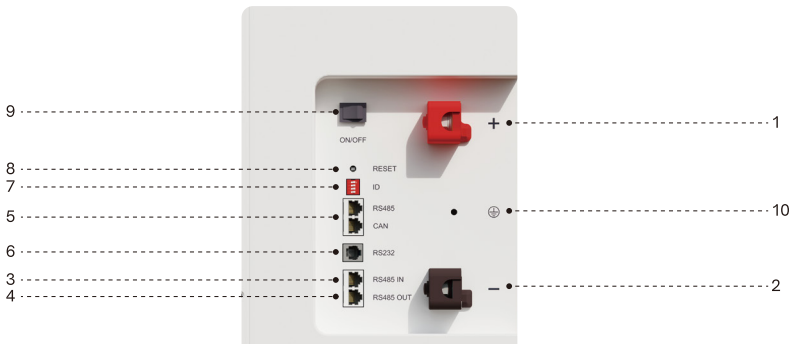

Serial number	Interface Name	Interface Definition
1	Positive terminal	The positive output of the battery is connected to the positive input terminal of the battery of the energy storage inverter through the positive cable of the battery
2	Negative terminal	The negative output of the battery is connected to the negative input terminal of the battery of the energy storage inverter through the negative cable of the battery
3	RS485 IN	When batteries are used in parallel: connect to the RS485 OUT interface of the previous battery via a communication cable
4	RS485 OUT	When batteries are used in parallel: connect to the RS485 IN port of the next battery via a communication cable
5	CAN/RS485	When the battery is used independently: connect to the CAN/RS485 interface of the energy storage inverter via a communication cable
6	RS232	Host computer debugging and use
7	ID	Dip switch
8	RESET	Reset switch
9	ON/OFF	Power switch
10	Grounding mark	Battery case ground connection

3 - PRODUCT INSTALLATION AND CONFIGURATION

3.1 Prepare tools

3.1.1 Preparation for installation of protective equipment

When installing the battery, you must wear the following protective gear:

Insulating gloves	Safety goggles	Safety shoes
-------------------	----------------	--------------

3.1.2 Installation tool preparation

The tools and instruments required are shown in the following table:

Power cable clamp	Pen	Phillips screwdriver	Flat head screwdriver
Wire strippers	Crimping pliers	Adjustable wrench	tape measure
Multimeter	Cylindrical head screwdriver	Torque wrench	Impact drill

3.2 Installation Requirements

3.2.1 Preparation for installation of protective equipment

- The installation location should be out of reach of children and avoid installation in a location that is easy to touch. The device may be hot during operation, so prevent burns.
- Ensure that there are no flammable, explosive or other dangerous items around the battery .
- The equipment protection level is limited to indoor installation only, and the temperature and humidity of the installation environment must be within the appropriate range.
- The installation site should be away from direct sunlight, conductive dust, salt fog and humid environment, and should be rainproof. Rain splashing is strictly prohibited.
- Please avoid water pipes, cables, etc. inside the wall when installing to avoid danger when drilling.

3.2.2 Installation space requirements

- Ensure there is sufficient space for the battery installation, and that the distance between the left and right sides of the battery exceeds 300mm.

3.2.3 Requirements for installation carrier

- The installation carrier cannot be made of flammable materials and must have fire-resistant properties.
- Ensure that the mounting surface is sturdy, reliable, and capable of supporting the weight of the device.
- The battery system should be installed close to the wall to prevent the battery from tipping over.











3.2.4 Installation angle requirements

- Ensure that the equipment is installed horizontally and not tilted or upside down.

3.3 Unpacking and Inspection

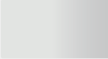
- Before unpacking, check the shipping list attached to each package and check that the outer packaging is intact.
- Be careful of bumps during unpacking.
- Check if the device model is correct, if not, do not open the package and contact your dealer.
- After unpacking, the professional installer should read the user manual and verify the packing list to ensure that the items are complete. If the internal packaging is damaged, it must be inspected and recorded in detail and reported to the dealer in a timely manner.

DHN-LVWES05-G1

Name	Specification	Quantity	Schematic diagram
Battery (standard)	51.2V/100Ah	1	
Battery positive cable (standard)	6AWG/L=1200mm/Red	1	
Battery negative cable (standard)	6AWG/L=1200mm/Black	1	
Communication cable (standard)	L=1200mm/ Dual RJ45 connector	1	
Battery hanging plate 1 (standard)	70×100×135mm	1	
Battery hanging plate 2 (standard)	70×100×135mm	1	
Battery mounting ear (standard)	34×40×30mm	2	
Positioning cardboard (standard)	500×480×3mm	1	
Expansion bolts (standard)	M6×60/Internal expansion type	6	
Cross recessed pan head combination screw (standard)	M4×10	4	
Hexagon socket head combination screw (standard)	M6×16	4	
Packing list (standard)	Packing List	1	

DHN-LVWES15-G1

Name	Specification	Quantity	Schematic diagram
Battery (standard)	51.2V/280Ah	1	
Battery positive cable (standard)	2AWG/L=1500mm/red	1	
Battery negative cable (standard)	2AWG/L=1500mm/black	1	
Communication cable (standard)	L=2000mm/Dual RJ45 connector /Black	2	
Grounding cable (standard)	10AGW/L=500mm yellow-green	1	
Battery hanging plate (standard)	530×218×188mm	1	
Battery mounting ear (standard)	40×30×50mm	2	
Positioning cardboard (standard)	520×680×5mm	1	
Expansion bolts (standard)	M8×80/Internal expansion type	6	
Cross recessed pan head combination screw (standard)	M4×8	4	
Cross recessed pan head combination screw (standard)	M5×8	1	
Hexagon socket head combination screw (standard)	M6×16	4	
Packing list (standard)	Packing List	1	
Quick Installation Manual (standard)	Quick Installation Manual	1	

3.4 Battery system installation

The battery can only be installed by personnel who have received electrical system training and have sufficient knowledge of the electrical system. During installation, always comply with the following and local safety regulations.

3.4.1 Floor Installation

When the battery is installed on the floor, two hanging ears must be used to connect the battery to the wall from the side to prevent it from tipping over.

- I. Use positioning cardboard to mark the positions of two mounting holes on the wall. The bottom of the cardboard must be in full contact with the ground. Reference “Figure a”.
- II. According to the marked positions, use an impact drill to drill two holes with a diameter of 12mm and a depth greater than 90mm to install the M6(for 5kWh) / M8(for 15kWh) expansion bolts. Reference “Figure b”.
- III. Fix the shell of the M6/M8 expansion bolt into the hole on the wall, and fix the mounting ear to the wall with an M6/M8 bolt, controlling the torque to 8N·m. Reference “Figure c”.
- IV. Transport the battery to the installation site and place it about 15mm away from the wall. Then use M4 cross-slot pan head combination screws to fix the mounting ears to the sides of the battery. Reference “Figure d”.

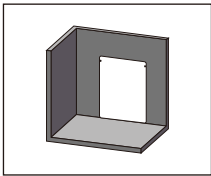

(Figure a)

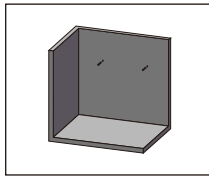

(Figure b)

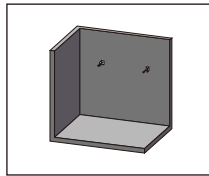

(Figure c)

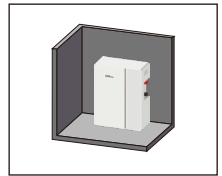

(Figure d)

3.4.2 Wall Mounting

- I. Use positioning cardboard to mark the positions of 6 mounting holes on the wall. The bottom of the cardboard must be perpendicular to the ground and about 300mm above the ground. Reference “Figure a”.
- II. According to the marked positions, use an impact drill to drill 6 holes with a diameter of 12mm and a depth greater than 90mm on the wall to install M6/M8 expansion bolts. Reference “Figure b”.
- III. Fix the shell of the M6/M8 expansion bolt into the hole on the wall, and use M6/M8 bolts to fix the hanging ears and hanging plates to the wall, controlling the torque to 5N·m(for 5kWh)/8N·m(for 15kWh). Reference “Figure c”.
- IV. Move the battery to the installed hanging plate, use M6 hexagon socket head combination screws to connect the hanging plate to the battery, and control the torque to 6N·m, then use M4 screws to connect the hanging ears to the battery, and control the torque to 1.5N·m. Reference “Figure d”.

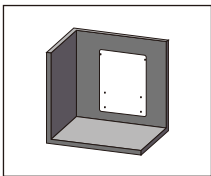

(Figure a)

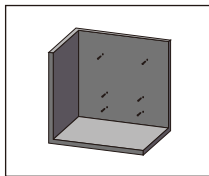

(Figure b)

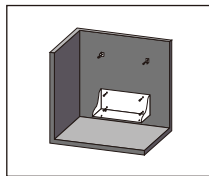

(Figure c)

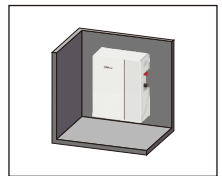

(Figure d)

3.4.3 Caster Installation (Optional)

The mounting holes of the casters with the mounting threaded holes at the bottom of the battery. Fix each caster with four M6 screws and keep the torque at 6Nm.

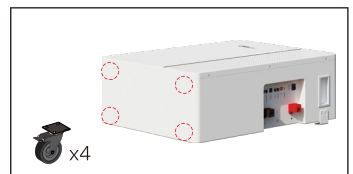

Note:

1. This is an optional configuration. Please check whether the model you purchased includes casters .
2. Install casters for easy movement. Please move the battery carefully and slowly to prevent the battery from tipping over .
3. After reaching the installation location, please refer to the floor installation or wall installation method to fix the battery.

3.5 Battery system wiring

Before connecting the battery system, use a multimeter to measure the continuity of the cables.

The measurement method is as follows:

Select the multimeter's beeper mode and test both ends of the same-color cable. If the beeper sounds, the cable is in good condition.

3.5.1 Ground connection

One end of the grounding cable to the grounding point of the battery casing and tighten it with an M5 screw . The tightening torque of the screw should be controlled at 3N·m to ensure a reliable connection and good conductivity . The other end should be connected and fixed to the grounding copper busbar inside the distribution cabinet to meet electrical safety standards and connection stability requirements, and to ensure the grounding integrity and effectiveness of the entire electrical system.

3.5.2 Power line connection

Connect the positive terminal of the battery to the positive terminal of the energy storage inverter through the positive battery cable, and then connect the negative terminal of the battery to the negative terminal of the energy storage inverter through the negative battery cable. The tightening torque of the cable terminal on the battery side is 8N·m. For the energy storage inverter side, refer to its manual.

Note:

1. Ensure that both the battery and the energy storage inverter are powered off before wiring. Reversing the positive and negative poles is strictly prohibited, as is any contact between the positive and negative terminals.

3.5.3 Communication line connection

The battery's CAN/RS485 port connects to the energy storage inverter's CAN/RS485 port using a communication cable. The communication cable is a standard network cable. If the customer's inverter is not compatible with the standard communication cable, please contact the dealer to obtain the correct PIN configuration. The PIN is defined as follows:

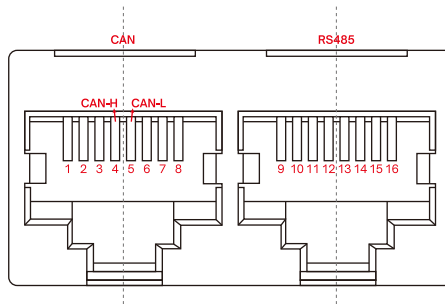

CAN--Using 8P8C vertical RJ45 socket		RS485--Using 8P8C vertical RJ45 socket	
RJ45 Pinout	Definition	RJ45 Pinout	Definition
1/3/6/7/8	NC	9/16	RS485-B1
4	CAN-H	10/15	RS485-A1
5	CAN-L	11/14	GND
2	GND	12/13	NC

Cable connection, refer to Figure 3-1 Single Battery Wiring Diagram .

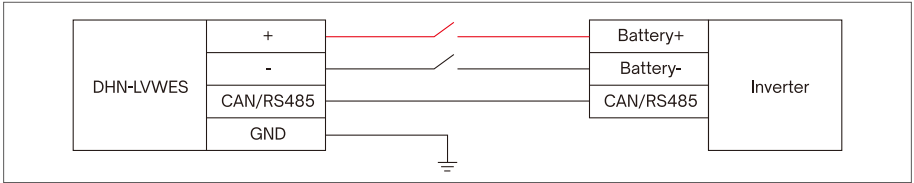

(Figure 3-1 Single battery wiring diagram)

Note:

1. If there are any problems during system connection , please contact your dealer to avoid damage to the equipment.

If multiple batteries are used in parallel, the connection method is as follows:

Supports up to 16 single-cell batteries in parallel.

Taking 3 batteries in parallel as an example. Need to use:

- 3 pairs of power cables
- 3 communication cables
- 1 junction box (according to system requirements) .

Cable connection reference Figure 3-2 Wiring diagram

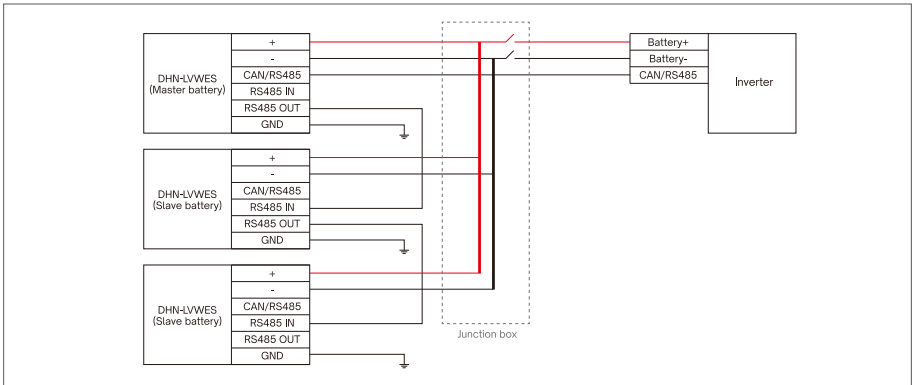

(Figure 3-2 Multiple parallel wiring diagram)

Parallel Operation Precautions:

The solution of customer's original system extension along with new battery (To add the new battery to the original system, you can refer to this plan.)

Step 1: Verify the battery serial number (SN). If the manufacturing date difference between the new and old batteries is within two years, capacity extension is allowed.

Step 2: Prior to the extension, ensure the original system is fully charged to 100% State of Charge (SOC), and the new battery is also charged to 100% SOC.

Important: Before parallel operation, verify the serial number (SN) of all batteries to ensure that the first six digits of the SN are identical. Batteries with the SN prefix 301201 are not compatible for parallel operation with batteries having the SN prefix 301202. Mixing them is strictly prohibited.

3.6 System Operation

3.6.1 Check before power on

When the battery system is powered on, be sure to check the following to prevent system damage.

Serial Number	Check Content
1	The batteries and energy storage inverters are installed firmly, the installation location is convenient for operation and maintenance, the installation space is convenient for ventilation and heat dissipation, and the installation environment is clean and tidy.

2	The protective ground wire, power wire, and communication wire are connected correctly and securely.
3	The cable bundling complies with the routing requirements, is reasonably distributed, and is not damaged.

3.6.2 Battery Power-up

Follow these steps to prime your battery:

1. Press the power switch button of the battery to the ON state. After the battery self-checks, the green LED lights will flash in sequence for 0.5s.
2. Use a multimeter to measure whether the voltage on the BAT+/BAT- terminals of the energy storage inverter is within the normal range (Refer to the datasheet).
3. After confirming that the battery output voltage and polarity are correct, turn on the energy storage inverter. For detailed operations, refer to the energy storage inverter user manual.
4. Check whether the communication between the energy storage inverter and the battery is normal. If the communication is abnormal, refer to 3.7 to match the corresponding communication protocol.

3.6.3 Parameter settings

Set the battery parameters on the energy storage inverter according to the recommended operating conditions of the battery :

Parameter	Setting Value	
	DHN-LVWES05-G1	DHN-LVWES15-G1
Maximum charging (constant voltage) voltage	58.4	57.6
Maximum charging current	100A	140A
Maximum discharge current	100A	140A

3.7 Matching Communication Protocol

[Note] Please note that this app only applies to 15kWh battery

Step 1: Download the APP

I. Scan the QR code to download .



Step 2: Enable APP dynamic permissions

II. Open the APP and select Allow when the pop-up boxes "Get Bluetooth Permission" (Figure a) and "Get Network Permission" (Figure b) appear.

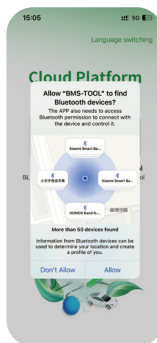

a

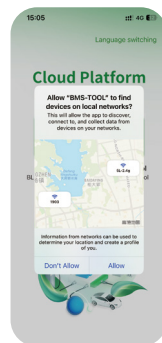

b

Step 3: Choose monitoring method

III. When the device is turned on, click the "Local Monitoring" button (Figure c), note the pop-up box "Get location permission" (Figure d), select Allow, search for the device (Figure e), and click the device to directly enter the device control page (Figure f).



c

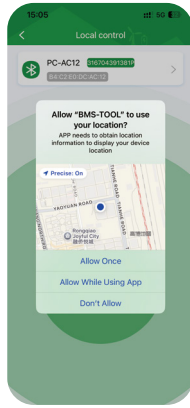

d

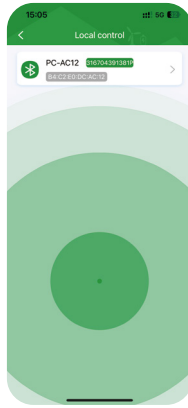

e



f

Step 4: Protocol Settings

IV. Set the protocol on the device information page. The factory default is PYLON protocol. If it matches the protocol, no changes are required (Figure g).

V. Select the corresponding protocol type according to the communication mode between the energy storage inverter and the battery, and click the protocol used by the matching energy storage inverter manufacturer (Figure h). If there is no corresponding protocol, contact the dealer.



g

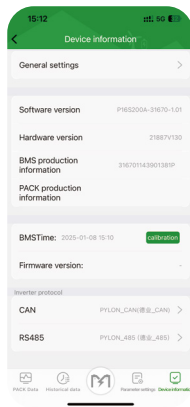

h

The above is the local monitoring method. Should you opt for the remote monitoring method, the following steps must be followed:

I. If you choose to enter via remote monitoring, new users must first select a country/region (Figure i) and complete email registration (Figure j).

II. After registration is complete, return to the login page and log in using your account and password (Figure k), then you can enter the Add Device page.

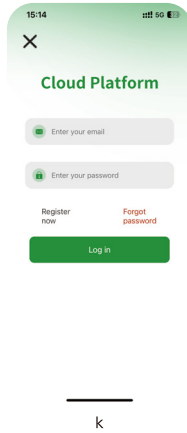
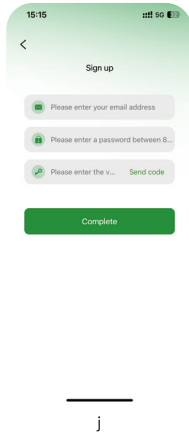
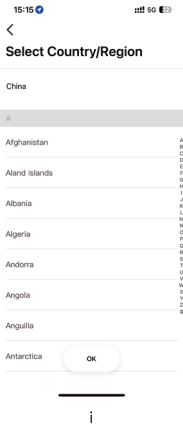

- III. Connect your mobile network to the corresponding Wi-Fi in advance (the frequency band must be 2.4GHz).
- IV. Click the "Add Device" button (Figure l), click Bind according to the page prompts (Figure m), enter the Wi-Fi account and password, click Next and wait for network configuration (Figure n).

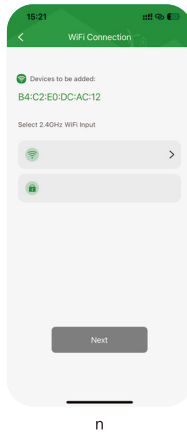
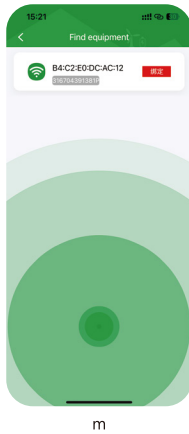
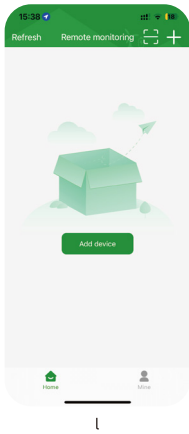

- V. After the network configuration is completed, it will automatically jump to the successful addition page. Click Save according to the page prompts (Figure o)
- VI. Click the device name (Figure p) to enter the device control page, view the device data and set parameters (Figure q)



o

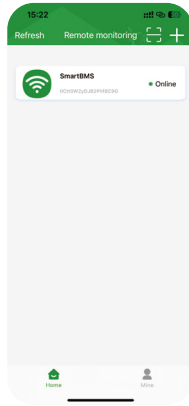

p

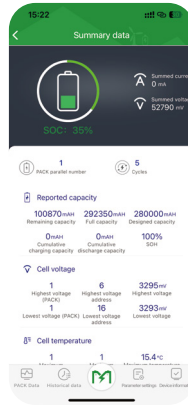

q

4 - TROUBLESHOOTING

4.1 Indicator Status

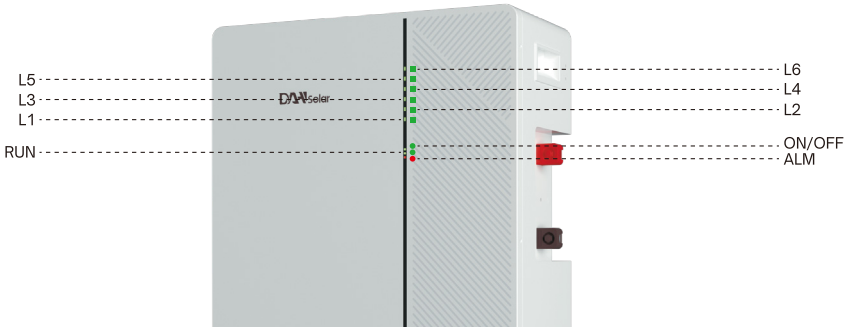

Model	State	ON/OFF	RUN	ALM	Battery Indicator					
					L6	L5	L4	L3	L2	L1
Shutdown	Hibernation	Off	Off	Off	Off	Off	Off	Off	Off	Off
Standby	Normal	Always on	Flash 1	Off	According to the power indicator (follow the rule that the number of lights on corresponds to the power level rising from 0% to 100%)					
	Alerts	Always on	Flash 1	Flash 3						
Charge	Normal	Always on	Always on	Off	According to the power indicator (the number of lights on corresponds to the power level from 0% to 100%, but there will be one light that keeps flashing, which means it is charging)					
	Alerts	Always on	Always on	Flash 3						
	Overcharge protection	Always on	Always on	Off	Always on	Always on	Always on	Always on	Always on	Always on
	Other protections	Always on	Off	Always on	Off	Off	Off	Off	Off	Off
Discharge	Normal	Always on	Flash 3	Off	According to the power indicator (follow the rule that the number of lights on corresponds to the power level rising from 0% to 100%)					
	Alerts	Always on	Flash 3	Flash 3						

Model	State	ON/OFF	RUN	ALM	Battery Indicator					
					L6	L5	L4	L3	L2	L1
		●	●	●	■	■	■	■	■	■
Discharge	Undervoltage protection	Always on	Off	Off	Off	Off	Off	Off	Off	Off
	Other protections	Always on	Off	Always on	Off	Off	Off	Off	Off	Off
Invalidation		Destroy	Off	Always on	Off	Off	Off	Off	Off	Off

Note: Flash 1 means on for 0.25S, off for 3.75S; Flash 2 means on for 0.5S, off for 0.5S; Flash 3 means on for 0.5S, off for 1.5S

4.2 Analysis and Treatment of Common Faults

When the battery protection mode is triggered or a system failure occurs, the ALM indicator on the front panel will light up (see Table 4-1 for the meaning of indicator status for specific status). When the battery is abnormal, please stop charging and discharging in time and find out the cause of the failure. If you cannot determine the cause, please contact the dealer in time.

Serial number	Fault phenomenon	Cause Analysis	Workaround
1	There is no output voltage at the positive and negative terminals of the battery, and the indicator light is off	The power switch is not turned on	Check the power switch
2	There is no output at the positive and negative terminals when the power switch is turned on	Device sleep	Press and hold the RESET button for 3 to 6 seconds or connect to a charger to activate
3	No DC output, red light is always on	Battery voltage is too low	Charging the battery system
4	The battery cannot be fully charged	Charging voltage is too low	Adjust the charging voltage within the range of 57.1-57.6V
5	Sparks are generated after the power cord is powered on, and the ALM indicator light is always on	Power line connection short circuit	Turn off the battery and check the cause of the short circuit
6	The device cannot be searched when adding a device on the mobile APP	Other users have not unbound the device after binding it	Press and hold the RESET button for 10 seconds. When all the indicator lights are on, only one light will be on (except the ON/OFF light). Release the button and the device will be discovered in the APP after 10 seconds.
7	Communication between the battery and the energy storage inverter is abnormal	Communication protocol does not match	Match the communication protocol according to 3.7

If you need any other technical assistance, please contact your dealer in time.

5 - MAINTAIN

Maintenance Items	Maintenance cycle
If the battery is not in use, it needs to be fully charged and then discharged to 25%-50%.	Every 6 months
Check whether the wall mount is loose, if so, tighten it.	Every 6 months
Check if the shell is damaged. If so, please repaint it or contact the dealer.	Every 6 months
Check whether the exposed wires are worn. If so, replace the corresponding cables or contact your dealer.	Every 6 months
Check whether there is any debris accumulated around the battery. If there is any, please clean it up to avoid affecting the heat dissipation of the battery.	Every 6 months
Check for water or pests to prevent long-term intrusion of the battery.	Every 6 months
<ul style="list-style-type: none"> • If you find any problem that may affect the battery or system, please contact the dealer. Unauthorized disassembly is prohibited. • If you find that the copper wire inside the conductive wire is exposed, do not touch it. There is a danger of high voltage. Please contact the dealer. Do not disassemble it without permission. • If other emergencies occur, please contact the dealer immediately and operate under the guidance of professional personnel, or wait for DAH Solar technical support to operate on site. 	

6 - BATTERY PARAMETERS

6.1 DHN-LVWES05-G1

Main Parameter

Battery Type	LiFePO4
Battery Rated Energy (kWh)	5.12
Battery Rated Capacity (Ah)	100
Scalability	Parallel connection of up to 16 units
Nominal Voltage (V)	51.2
Operating Voltage(V)	43.2~58.4
Charge/Discharge Current (A)–Recommend	50
Charge/Discharge Current (A)–Max.	100

Other Parameter

Recommend Depth of Discharge(%)	≤90
System Dimension (W/H/D, mm)	480×500×155
System Weight (kg)	47
Master LED Indicator	6LED (SOC:16.6%~100%), 3LED (ON/OFF,RUN,ALARM)
IP Rating of Enclosure	IP20
Operating Temperature(°C)	Charge:0~+60/Discharge:-20~+60
Storage Temperature(°C)	-20~+35
Cycle Life (25±2°C,0.5C/0.5C,70%EOL)	≥6000
Installation	Wall–Mounted/Floor–Mounted
Fire Prevention System	Prefabricated whole fluorine ketone fire extinguishing device (optional)
Communication Methods	CAN2.0/RS485
Warranty Period (years)	10
Certification	IEC62619–CB,CE,UN38.3
Compatible Inverters	SMA/VICTRON/SE/DEYE/SOLIS/GOODWE/GROWATT/ LUXPOWERTEK/SENERGY/SRD etc

6.1 DHN-LVWES15-G1

Main Parameter

Battery Type	LiFePO4
Battery Rated Energy (kWh)	14.34
Battery Rated Capacity (Ah)	280
Scalability	Parallel connection of up to 16 units
Nominal Voltage (V)	51.2
Operating Voltage(V)	43.2~57.6
Charge/Discharge Current (A)–Recommend	140
Charge/Discharge Current (A)–Max.	200

Other Parameter

Recommend Depth of Discharge(%)	≤90
System Dimension (W/D/H, mm)	520×680×232
System Weight (kg)	114
Master LED Indicator	6LED (SOC:16.6%~100%), 3LED (ON/OFF,RUN,ALARM)
IP Rating of Enclosure	IP20
Operating Temperature(°C)	Charge:0~+55/Discharge:-20~+55
Storage Temperature(°C)	-20~+35
Humidity (%)	5~95
Altitude (m)	≤2000
Cycle Life (25±2°C,0.5C/0.5C,70%EOL)	≥8000
Installation	Wall–Mounted/Floor–Mounted (optional wheel)
Fire Prevention System	Prefabricated whole fluorine ketone fire extinguishing device (optional)
Communication Methods	CAN2.0/RS485
Warranty Period (years)	10
Certification	IEC62619–CB,CE,UN38.3
Compatible Inverters	SMA/VICTRON/SE/DEYE/SOLIS/GOODWE/GROWATT/ LUXPOWERTEK/SENERGY/SRD etc



DAH Solar Co., Ltd.

Add: No.1 Yaoyuan Road, Luyang District, Hefei City, Anhui, China

E-mail: info@dahsolar.com

en.dahsolar.com

VERSION: 20260126