

DATA SHEET



Three Phase Induction Motor - Squirrel Cage

Customer : MGE
Customer reference : MGE

Product line : W20 Three-Phase Product code : 16400125

Frame	: 80	Locked rotor time	: 46s (cold) 26s (hot)
Output	: 1.1 kW (1.5 HP)	Temperature rise	: 80 K
Poles	: 2	Duty cycle	: S1
Frequency	: 50 Hz	Ambient temperature	: -20°C to +40°C
Rated voltage	: 230/400 V	Altitude	: 1000 m.a.s.l.
Rated current	: 3.98/2.29 A	Protection degree	: IP55
L. R. Amperes	: 24.7/14.2 A	Cooling method	: IC411 - TEFC
LRC	: 6.2	Mounting	: B3T
No load current	: 2.08/1.19 A	Rotation ¹	: Both (CW and CCW)
Rated speed	: 2820 rpm	Noise level ²	: 59.0 dB(A)
Slip	: 6.00 %	Starting method	: Direct On Line
Rated torque	: 3.73 Nm	Approx. weight ³	: 11.2 kg
Locked rotor torque	: 350 %		
Breakdown torque	: 340 %		
Insulation class	: F		
Service factor	: 1.00		
Moment of inertia (J)	: 0.0009 kgm ²		
Design	: N		

Output	50%	75%	100%	Foundation loads	
Efficiency (%)	82.0	82.7	82.7	Max. traction	: 350 N
Power Factor	0.64	0.77	0.84	Max. compression	: 460 N

Losses at normative operating points (speed;torque), in percentage of rated output power

P1 (0,9;1,0)	P2 (0,5;1,0)	P3 (0,25;1,0)	P4 (0,9;0,5)	P5 (0,5;0,5)	P6 (0,5;0,25)	P7 (0,25;0,25)
20.4	18.0	16.5	10.5	7.1	5.0	3.4

	Drive end	Non drive end
Bearing type	: 6204 ZZ	: 6203 ZZ
Sealing	: V'Ring	: V'Ring
Lubrication interval	: -	: -
Lubricant amount	: -	: -
Lubricant type	: Mobil Polyrex EM	

Notes

This revision replaces and cancel the previous one, which must be eliminated.

- (1) Looking the motor from the shaft end.
- (2) Measured at 1m and with tolerance of +3dB(A).
- (3) Approximate weight subject to changes after manufacturing process.
- (4) At 100% of full load.

These are average values based on tests with sinusoidal power supply, subject to the tolerances stipulated in IEC 60034-1.

Rev.	Changes Summary	Performed	Checked	Date
Performed by				
Checked by			Page	Revision
Date	29/09/2023		1 / 1	

1 2 3 4 5 6

A
B
C
D
E

Grounding for leads 0.5–6 mm² / 20–10 AWG

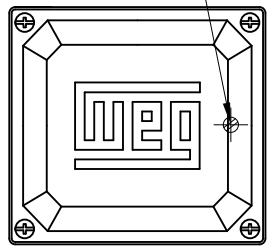
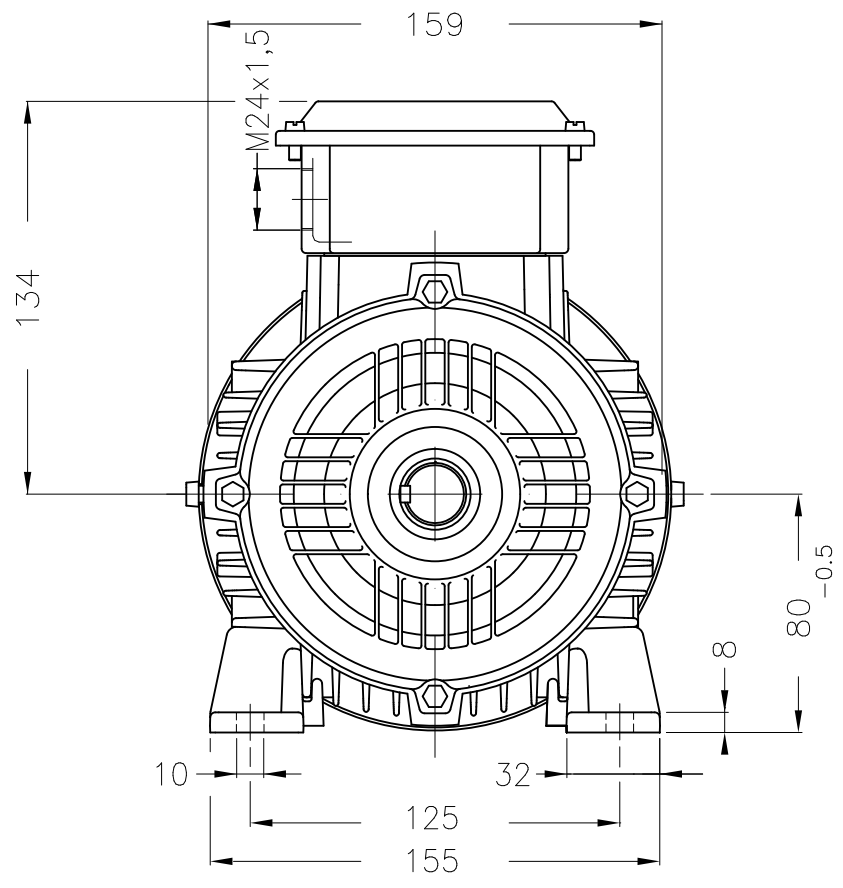

View X

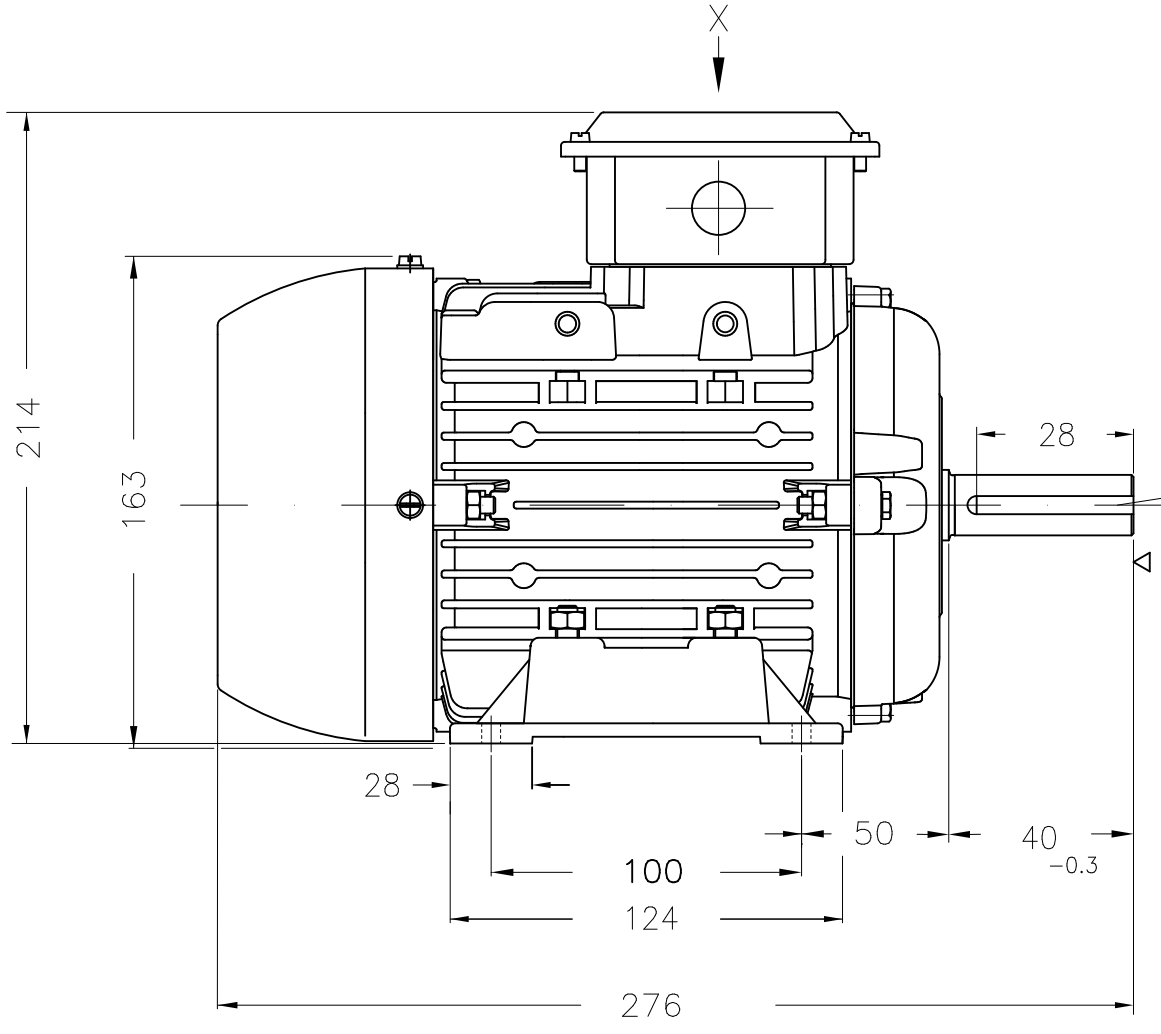

Center hole
DM6 WEG WPR-7339
(DIN 332)

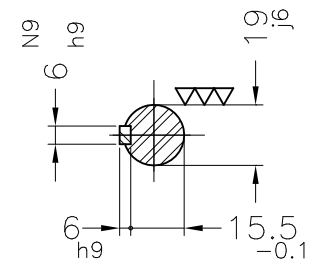

DE Shaft End

Color RAL 5009					
Painting plan 201A					
Mounting B3T					
				HYBRISUSER	00
ECM	LOC	SUMMARY OF MODIFICATIONS		EXECUTED	CHECKED
EXECUTED	HYBRISUSER	THREE PH. MOTOR W20 GB3			
CHECKED		FRAME 80 IP55 TEFC			
RELEASED					
REL. DATE		WMO	Jaragua do Sul	Product Engineering	
				PREVIEW	
				WDD	00
				SHEET	1 / 1

1.1 kW 02 Poles 50 Hz

A

Dimensions in mm XME A3

